



System for the automation of surface inspection using new machine vision and deep learning techniques

Fernando Menéndez Menéndez
fermenen.com



Universidad de
Oviedo



Gonvarri
Industries

Industrial context - Pickling process



Before



After

Related work

**Foucault
currents**

**Ultrasonic
system**

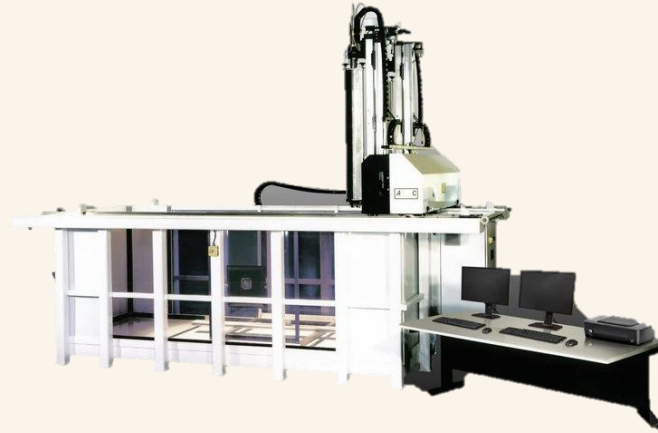

Working scenario



27 different defect types

Abolladuras

Arañazos

Bordes rotos

Bordes rotos

Cascarilla

Cazuela

Cordón de
soldadura

Soja

Etiqueta

Huella de
cascarilla

Huella de óxido

Incrustaciones

Lateral doblado

Manchas de
aceite

Óxido

Ondulaciones

...

Working scenario

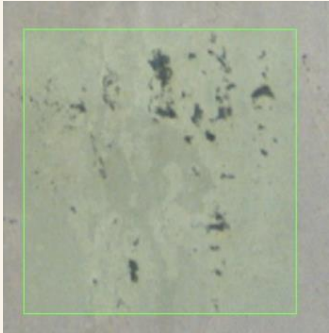

Oxide



Label

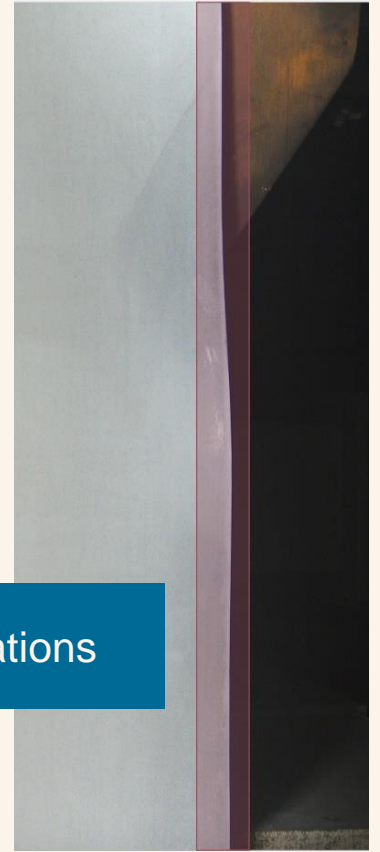

Ondulations

Solution specification

Basler ace acA4096-11gc, Focal 12 mm
Distance: 1.30 m, Camera FOV perp: 1.53 x 0.81 m
ROI: 1.52 x 0.90 m, Pixel resolution: 0.37 mm

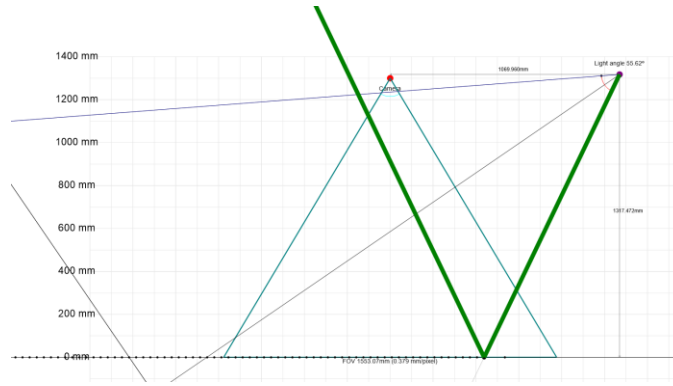
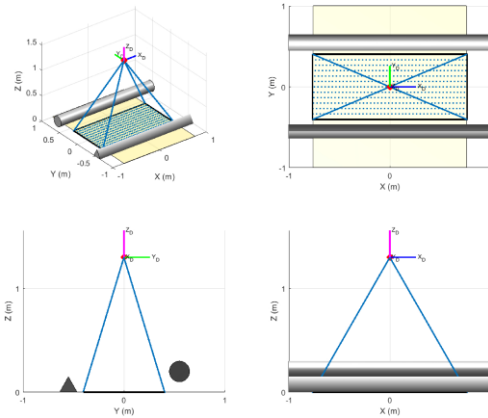

IMX267
Sensor

12 fps
Frame rate

9 MP
Resolution

Lighting



Secom ESDIUM

Gonvarri spotlight



Philips GentleSpace



Luminalia



Normalit Blok



Normalit Avant



Gantries

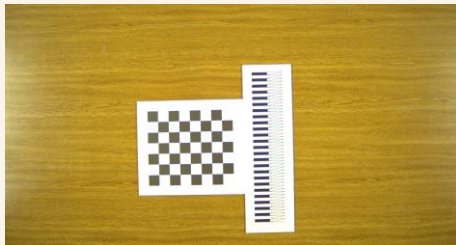
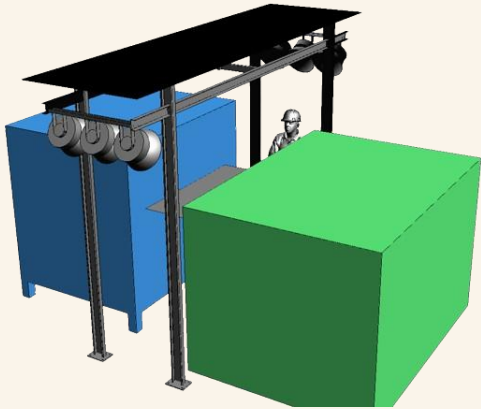

180 cm

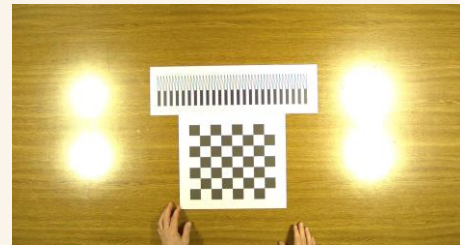
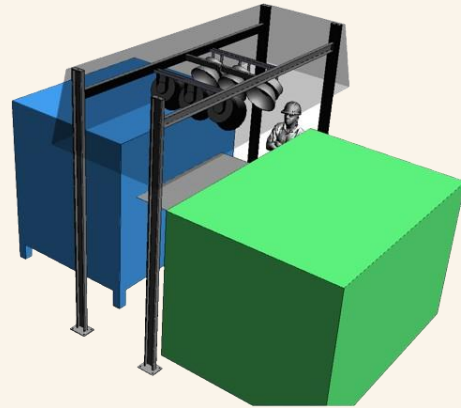

50 cm

Colour calibration



Continuous learning process

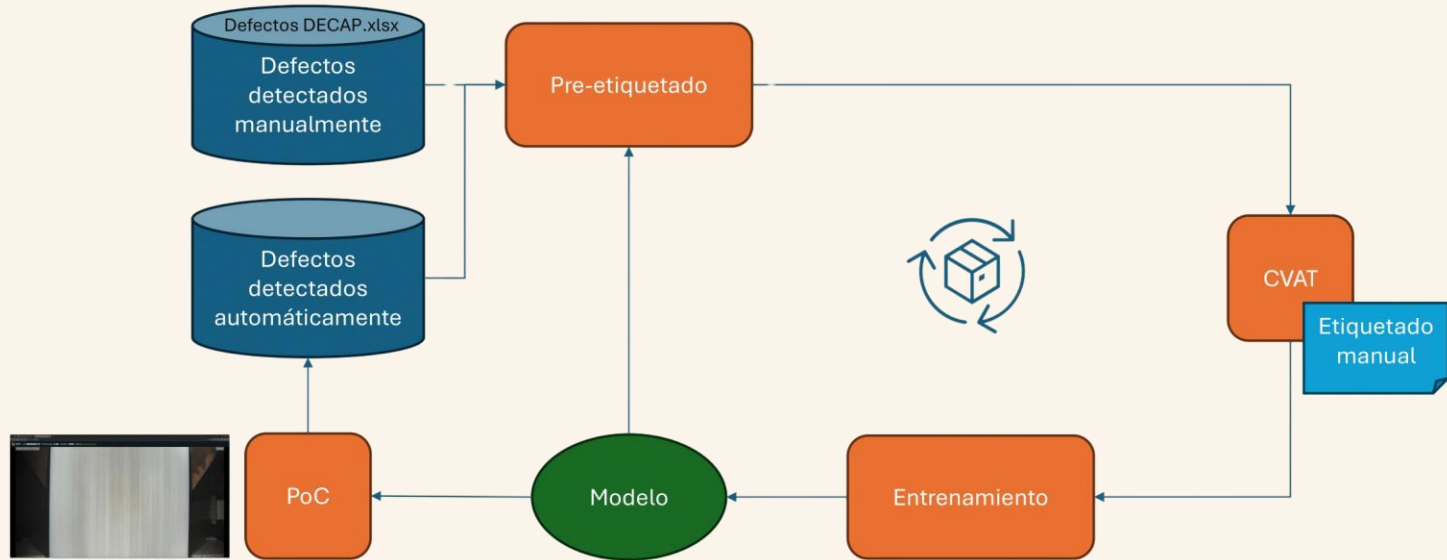

Real Time restrictions

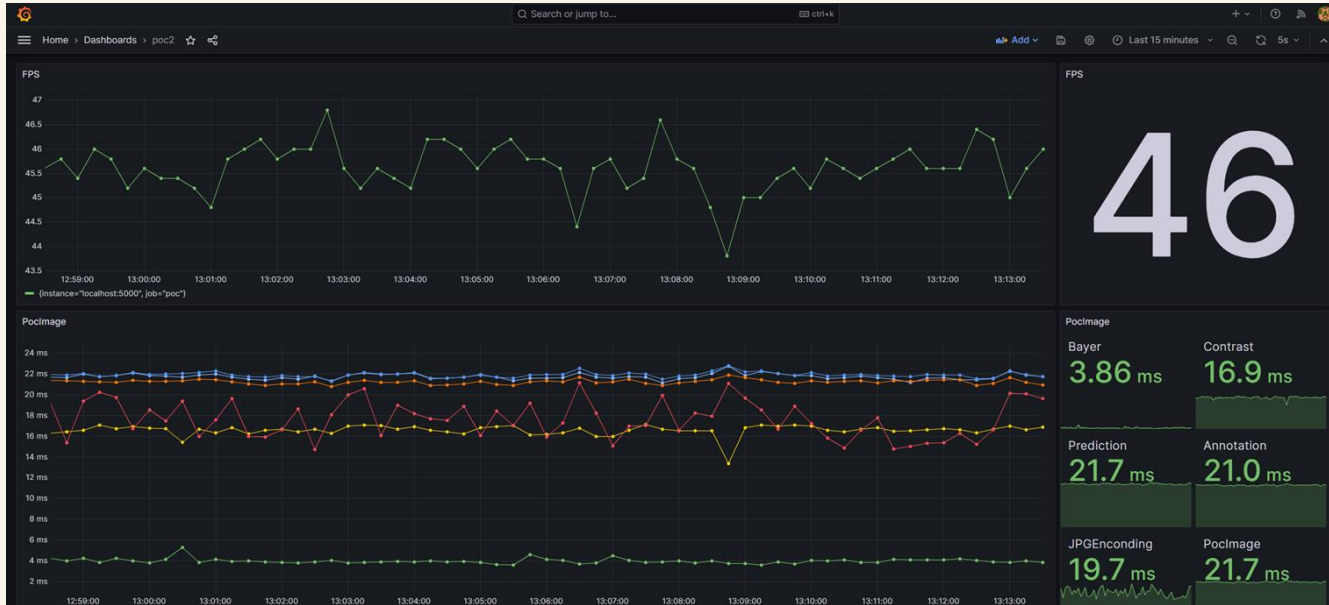

Dataset D006B - 15 December 2023

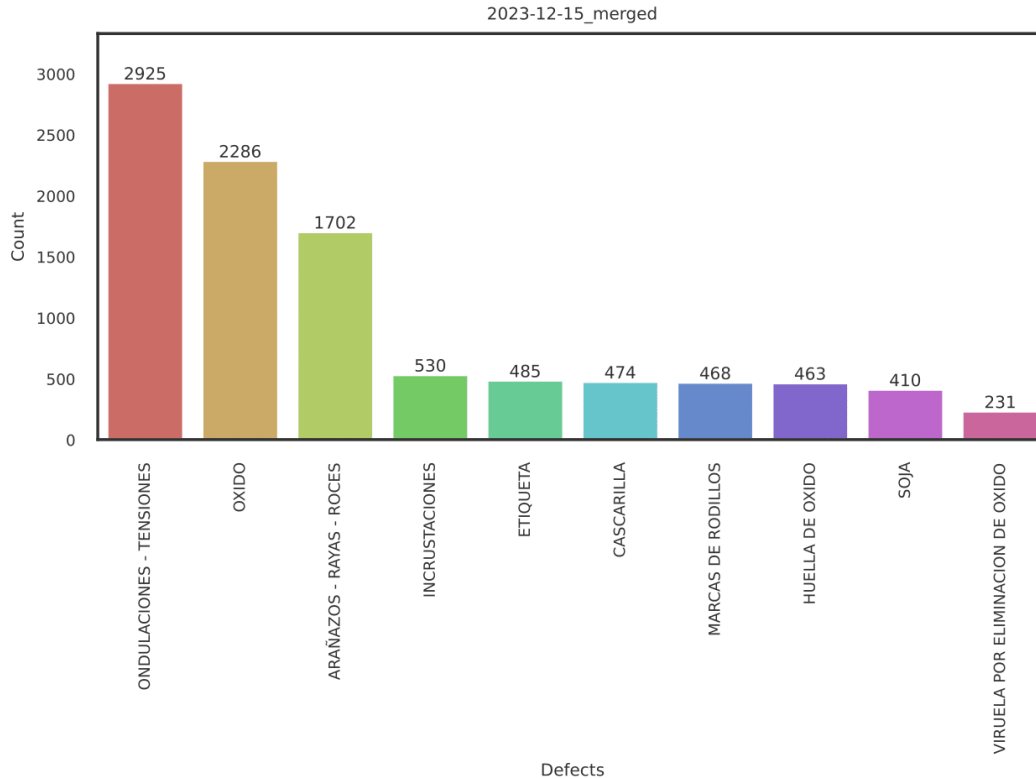

F1

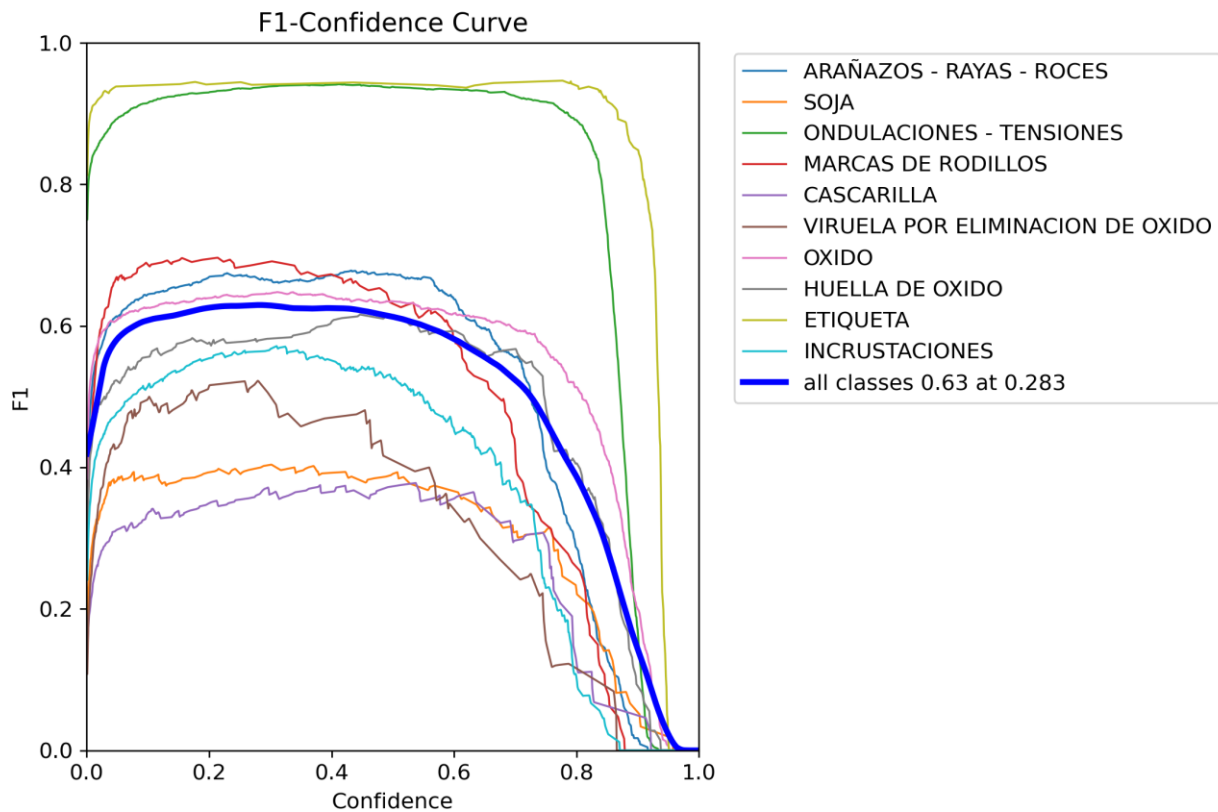

Results

Clase	P	R	F1	mAP50	mAP50-95
Arañazos - Rayas - Roces	0.806	0.687	0.742	0.71	0.335
Soja	0.601	0.486	0.537	0.439	0.217
Ondulaciones - Tensiones	0.952	0.961	0.956	0.975	0.604
Marcas de rodillos	0.647	0.508	0.569	0.558	0.223
Cascarilla	0.421	0.371	0.394	0.347	0.127
Viruela por eliminación de óxido	0.639	0.328	0.433	0.352	0.137
Óxido	0.672	0.556	0.609	0.565	0.324
Huella de óxido	0.58	0.483	0.527	0.511	0.276
Etiqueta	0.894	0.892	0.893	0.915	0.777
Incrustaciones	0.515	0.564	0.538	0.529	0.186
All	0.673	0.584	0.625	0.59	0.321

Metrics by image

Sensitivity
91 %

Specificity
98 %

Pickled desk with PoC inspection system

